



profiset

Automatic **planers and throughfeed moulders.**

profiset 60

Versatile, safe and high performance.

The planers / throughfeed moulders are sturdy machines with high quality components to always ensure the very best performance.

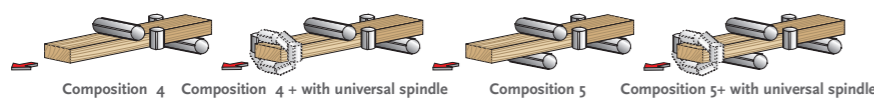

Available in 4 different compositions: 4/5 spindles and the possibility to use the universal spindle in order to meet any profiling requirement.

AUTOMATIC PLANERS AND THROUGHFEED MOULDERS

PROFISSET 60

| | | |
|--|-------|---------|
| Min/max working width (finished section) | mm | 25/230 |
| Min/max working height (finished section) | mm | 6/120 |
| Feed speed | m/min | 5÷25 |
| Spindles speed | rpm | 6000 |
| Spindles diameter | mm | 40 |
| Min/max cutterheads diam. planer group | mm | 120÷140 |
| Min/max cutterheads diam. vertical spindles length | mm | 100÷180 |
| Min/max cutterheads diam. on top horizontal spindle | mm | 125 |
| Min/max cutterheads diam. on bottom horizontal spindle | mm | 100÷180 |
| Min/max cutterheads diam. universal spindle | mm | 100÷180 |
| Vertical spindles length | mm | 140 |
| Horizontal spindles length | mm | 250 |
| Universal spindles length | mm | 240 |
| Feed rollers diameter | mm | 120 |
| Infeed table length | mm | 2000 |
| Manual pump for table lubrication | | STD |
| Manual centralised lubrication | | STD |

main devices



THE OPTIMUM FEEDING: MORE PRODUCTIVITY AND IMPROVED FINISHING.

- Gears box drive and cardan joints
- Pneumatic working pressure on the feed rollers
- inverter for the stepless speed adjustment from 5 to 25 m/min

SET UP: TOP SETTING-UP SPEED.

The system has the minimum tool diameter as only reference. A single adjustment to position all the elements and no idle retooling times.

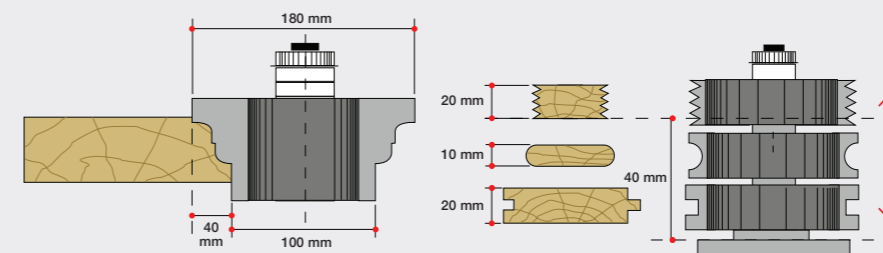
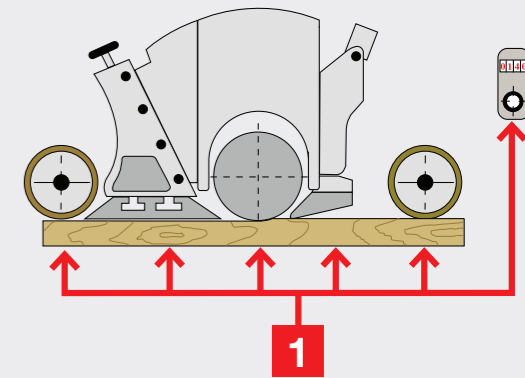

HIGH PERFORMANCE AVAILABLE AS STANDARD.

The vertical spindles allow a profiling capacity of up to 40mm and an axial adjustment of 40mm to manage more profiles.

T-SET RAPID TOOL LOCKING DEVICE: MAXIMUM DEGREE OF SAFETY WITHOUT ANY EFFORTS.

It ensures the locking/unlocking of tools simply through a gun with compressed air.



profiset 40

Versatile, ergonomic and safe.

Maximum compactness with minimum overall dimensions to safeguard the essential space for the operator.

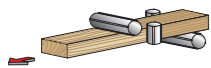

4 spindles machine composition with 10mm profiling capacity on the vertical spindles.

| AUTOMATIC PLANER AND THROUGHFEED MOULDER | | PROFISSET 40 |
|--|-------|--------------|
| Min/max working width (finished section) | mm | 23/180 |
| Min/max working height (finished section) | mm | 6/105 |
| Feed speed | m/min | 6-12 |
| Spindles speed | rpm | 6000 |
| Spindles diameter | mm | 35 |
| Min/max cutterheads diam. on planer group unit | mm | 100 |
| Min/max cutterheads diam. on vertical spindles | mm | 100÷120 |
| Min/max cutterhead diam. on top horizontal spindle | mm | 100 |
| Vertical spindles length | mm | 120 |
| Horizontal spindles length | mm | 190 |
| Feed rollers diameter | mm | 120 |
| Infeed table length | mm | 1700 |
| Manual pump for table lubrication | | STD |
| Manual centralised lubrication | | STD |

main devices



IDLE ROLLER PLACED ON THE TABLE: THE BEST FINISHING.

Improved feeding due to the idle roller placed on the outfeed table, typical feature of industrial level machines.

ALWAYS READY TO USE.

The profiset 40 "ep" (CNC version with electronic control) automatically controls the working sections; the feed speed is equipped with only one push button for the sequential motors start.



"READY" ELECTRONIC CONTROL: WORK PROGRAMMING BECOMES SIMPLE AND EFFECTIVE.

- Automatic positioning control of left vertical spindle and top horizontal spindle
- Feed speed programming
- Mode: manual, semiautomatic and automatic with memory capacity up to 99 programs.
- Additional functions: calculator and hour counter.



ERGONOMICS AND SAFETY.

The operator easily manages every working operation due to all controls at your fingertips.

The manual pump for the **worktable lubrication** positioned in the working area facilitates its use, assuring always the **best smooth movement** of the work piece (standard).



profiset

Overall dimensions.

PROFISET 60

dimensions

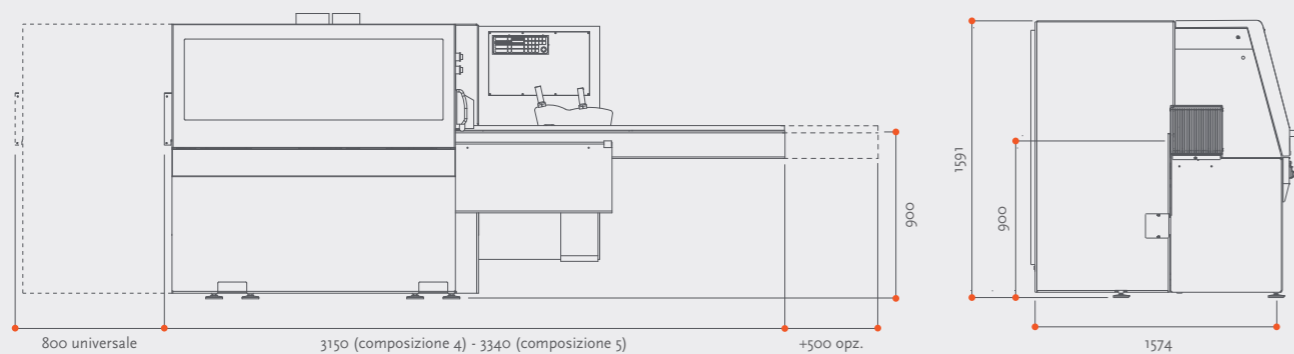

PROFISET 40

dimensions

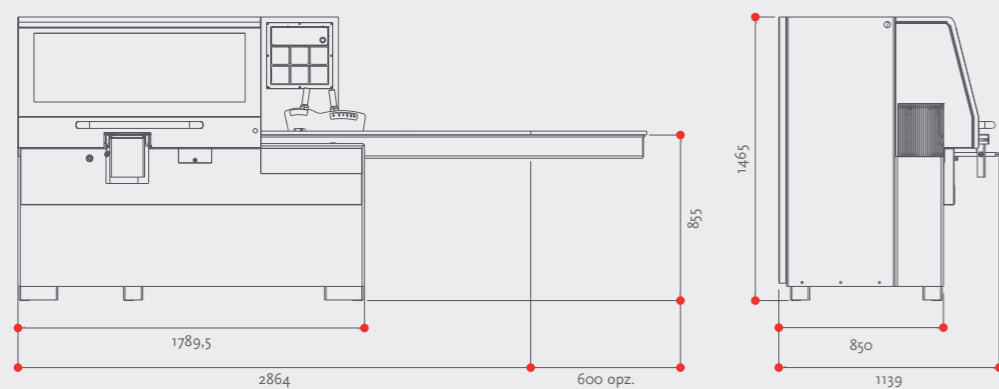

The best global partner that is very close to woodworking companies.



SIN&ERT



The technical data can vary according to the requested machine composition. In this catalogue, machines are shown with options. The company reserves the right to modify technical specifications without prior notice; the modifications do not influence the safety foreseen by the CE Norms.



SCM GROUP SPA SCM - via Casale 450 - 47826 Villa Verucchio, Rimini - Italy
tel. +39 0541 674111 - fax +39 0541 674274 - scm@scmgroup.com - www.scmgroup.com



00L0076966B